

ATTACHMENT B – NOTICE OF INTENT FORM

Each Discharger must complete and submit a Notice of Intent (NOI) to apply for an Authorization to Discharge under NPDES Permit No. CAG912004.

This Notice of Intent form is for the facility located at (provide street address):

I. CERTIFICATION

This certification must be signed in accordance with Attachment D section V.B.2. The Discharger hereby agrees to comply with and be responsible for all the conditions specified in NPDES Permit No. CAG912004.

I certify under penalty of law that this document and all attachments were prepared under my direction or supervision in accordance with a system designed to assure that qualified personnel properly gather and evaluate the information submitted. Based on my inquiry of the person or persons who manage the system or those directly responsible for gathering the information, the information submitted is, to the best of my knowledge and belief, true, accurate, and complete. I am aware that there are significant penalties for submitting false information, including the possibility of fine and imprisonment for knowing violations.

Signature

Date

Printed Name

Title

Company / Organization

Land Owner Type (Check One)

 Public Private Other, specify the type:

Address

Email

Phone No.

II. APPLICATION FEE AND MAILING INSTRUCTIONS

Submit a check payable to “State Water Resources Control Board” for the appropriate application fee to the following address:

San Francisco Bay Regional Water Quality Control Board
Attn: NPDES Wastewater Division
1515 Clay Street, Suite 1400
Oakland, CA 94612

Submit this form (with signature and attachments) via email to R2NPDES@waterboards.ca.gov or as otherwise indicated at

www.waterboards.ca.gov/sanfranciscobay/water_issues/programs/general_permits.shtml.

III. DISCHARGE TYPE

Permit Coverage Status (select one): <input type="checkbox"/> This is a new discharge. <input type="checkbox"/> This discharge is currently authorized under this Order and this NOI is to modify the current Authorization to Discharge. CIWQS Place ID: _____ <input type="checkbox"/> This discharge is currently authorized under this Order and this NOI is to continue discharging after July 31, 2023 (NOI is due November 3, 2022). CIWQS Place ID: _____ Category (select one): <input type="checkbox"/> Category 1: Aquifer reclamation program well discharges. <input type="checkbox"/> Category 2: Reverse osmosis (RO) concentrate from aquifer reclamation program well discharges. <input type="checkbox"/> Category 3: Structural dewatering discharges of 10,000 gallons per day or greater requiring treatment.

IV. PROJECT INFORMATION

Type of Site or Project: (e.g., structural dewatering project)
Project Tentative Completion Date (if any):

V. UTILITY INFORMATION

I have contacted the local sanitary sewer agency serving the above named address and determined that discharging to the local sanitary sewer system is not technically and economically feasible. Please check one (if No or Not Applicable, please explain) <input type="checkbox"/> Yes <input type="checkbox"/> No: <input type="checkbox"/> Not Applicable:	
Contact Person's Name and Title	
Contact Person's Email	Contact Person's Phone No.
I have contacted the local agencies having jurisdiction over the use of the storm drain system or watercourse and informed them about this proposed discharge. Please check one (if No or Not Applicable, please explain) <input type="checkbox"/> Yes <input type="checkbox"/> No: <input type="checkbox"/> Not Applicable:	
Contact Person's Name and Title	
Contact Person's Email	Contact Person's Phone No.

VI. FACILITY INFORMATION

A. Facility Name:			
Street Address			
City	State	Zip Code	Phone No.
Contact Person's Name and Title			
Contact Person's Email		Contact Person's Phone No.	
<p>Duly Authorized Representative: The following individual (or any individual occupying the position listed below) may act as the facility's duly authorized representative and may sign and certify submittals in accordance with Attachment D section V.B.3. The individual is responsible for the overall operation of the facility or for facility environmental matters. IMPORTANT: See section XI.F.2 below for further instructions.</p>			
Name			
Title			
Company/Organization			
Street Address			
City	State	Zip Code	Phone No.
Email			
B. Billing Information			
Name			
Street Address			
City	State	Zip Code	Phone No.
Email			
C. Design Professional Engineer's Information (see Section XI.F.4 for further instructions)			
Name		California License Number Expiration Date	
Street Address			
City	State	Zip Code	Phone No.
Email			
D. Operation and Maintenance Professional Engineer's Information (see Section XI.F.5 for further instructions)			
Name		California License Number Expiration Date	
Street Address			
City	State	Zip Code	
Email			

E. Consulting Firm's Information (see section XI.F. for further instructions)			
Contact Person	Company Name		
Street Address			
City	State	Zip Code	Phone No.
Email			

VII. DISCHARGE LOCATION INFORMATION

Receiving Water Name:			
Discharge path to Receiving Water - describe the complete path of the discharge from the exit point of the treatment system to the outfall in the receiving water – list streets, land features, and distances as necessary.			
Discharge Points	Latitude¹	Longitude¹	
Effluent Monitoring Location (EFF-001 through EFF- <i>n</i>)			
Entry Point to Storm Drain (if applicable)			
Receiving Water (directly or via storm drain system)			
Upstream Receiving Water Monitoring Location (RSW-001U through RSW- <i>nU</i>) ²	Is access unrestricted? <input type="checkbox"/> Yes <input type="checkbox"/> No		
	If No, explain:		
Downstream Receiving Water Monitoring Location (RSW-001D through RSW- <i>nD</i>) ³	Is access unrestricted? <input type="checkbox"/> Yes <input type="checkbox"/> No		
	If No, provide details:		

1. Submit latitude and longitude coordinates in decimal degrees with 5 significant figures to the right of the decimal point.
 2. At a point 50 feet upstream from the point of discharge into the receiving water, or if access is limited, at the first point upstream which is accessible.
 3. At a point 50 feet downstream from the point of discharge into the receiving water, or if access is limited, at the first point downstream which is accessible.
- Check here if information for additional outfalls is attached to this form.

VIII. TREATMENT SYSTEM INFORMATION

A. General Information		
Groundwater Treatment Design Capacity (gpm) as certified by a Professional Engineer licensed to practice in California.		
Discharge description (describe discharge and potential pollutants of concern). Attach additional sheets if needed:		
Discharge Frequency: <input type="checkbox"/> Continuous <input type="checkbox"/> Daily <input type="checkbox"/> Intermittent <input type="checkbox"/> Emergency (explain):		
Estimated Total Water Reclaimed (%): Provide reasons if reclamation is not technically and economically feasible:	Type of Reclamation (e.g., landscape irrigation):	
B. Unit Information		
Type	Number	Description (e.g., depth, size, capacity, dosage)
Extraction wells or sump pumps		
Extraction wells with dedicated treatment units		
Settling tanks in series		
Settling tanks in parallel		
Oil-water separators		
Filters for particulates in groundwater		
De-chlorination Unit (applies to Dischargers that chlorinated their well water)		
Granular activated carbon (GAC) vessels in series		
Granular activated carbon (GAC) vessels in parallel		
Chemical additive(s) (e.g., coagulants)		
Other tanks (e.g., equalization tank)		
Water reclamation tanks		

Energy Dissipator System		
Other BMPs (e.g., range of the RO facility blending ratio)		
Other treatment units (e.g., ion exchange, reverse osmosis)		

IX. DISCHARGE WATER QUALITY

For existing dischargers, summarize influent and effluent monitoring data collected during the past five years. Provide a separate data summary table for each monitoring location. New applicants shall summarize influent data.

A. INFLUENT DATA - Summarize influent monitoring data for each influent monitoring location (INF-*n*) and list them sequentially.

Influent Monitoring Location. _____ - Conventional and Non-Conventional Pollutants

Parameter	Units	Average Monthly Effluent Limitation	Maximum Daily Effluent Limitation	Maximum Concentration	Range	Method Detection Limit	Test Method	Number of Samples
Turbidity	NTU							
Chloride	mg/L							
Total Dissolved Solids	mg/L							
Chlorine Residual	mg/L							

Influent Monitoring Location. _____ - Priority Pollutants

CTR No.	Parameter	Units	Average Monthly Effluent Limitation	Maximum Daily Effluent Limitation	Maximum Concentration	Range	Method Detection Limit	Test Method	Number of Samples
1	Antimony	µg/L							
2	Arsenic	µg/L							
3	Beryllium	µg/L							
4	Cadmium	µg/L							
5a	Chromium (III)	µg/L							
5b	Chromium (VI)	µg/L							
6	Copper	µg/L							
7	Lead	µg/L							
8	Mercury	µg/L							
9	Nickel	µg/L							
10	Selenium	µg/L							
11	Silver	µg/L							
12	Thallium	µg/L							
13	Zinc	µg/L							
14	Cyanide	µg/L							
16	2,3,7,8-TCDD (Dioxin)	µg/L							
17	Acrolein	µg/L							
18	Acrylonitrile	µg/L							
19	Benzene	µg/L							
20	Bromoform	µg/L							
21	Carbon Tetrachloride	µg/L							
22	Chlorobenzene	µg/L							
23	Chlorodibromomethane	µg/L							
24	Chloroethane	µg/L							
25	2-Chloroethylvinyl ether	µg/L							
26	Chloroform	µg/L							
27	Dichlorobromomethane	µg/L							
28	1,1-Dichloroethane	µg/L							
29	1,2-Dichloroethane	µg/L							
30	1,1-Dichloroethylene	µg/L							
31	1,2-Dichloropropane	µg/L							
32	1,3-Dichloropropylene	µg/L							
33	Ethylbenzene	µg/L							
34	Methyl Bromide	µg/L							
35	Methyl Chloride	µg/L							
36	Methylene Chloride	µg/L							

CTR No.	Parameter	Units	Average Monthly Effluent Limitation	Maximum Daily Effluent Limitation	Maximum Concentration	Range	Method Detection Limit	Test Method	Number of Samples
37	1,1,2,2-Tetrachloroethane	µg/L							
38	Tetrachloroethylene	µg/L							
39	Toluene	µg/L							
40	1,2-Trans-Dichloroethylene	µg/L							
41	1,1,1-Trichloroethane	µg/L							
42	1,1,2-Trichloroethane	µg/L							
43	Trichloroethylene	µg/L							
44	Vinyl Chloride	µg/L							
45	2-Chlorophenol	µg/L							
46	2,4-Dichlorophenol	µg/L							
47	2,4-Dimethylphenol	µg/L							
48	2-Methyl- 4,6-Dinitrophenol	µg/L							
49	2,4-Dinitrophenol	µg/L							
50	2-Nitrophenol	µg/L							
51	4-Nitrophenol	µg/L							
52	3-Methyl 4-Chlorophenol	µg/L							
53	Pentachlorophenol	µg/L							
54	Phenol	µg/L							
55	2,4,6-Trichlorophenol	µg/L							
56	Acenaphthene	µg/L							
57	Acenaphthylene	µg/L							
58	Anthracene	µg/L							
59	Benzidine	µg/L							
60	Benzo(a)Anthracene	µg/L							
61	Benzo(a)Pyrene	µg/L							
62	Benzo(b)Fluoranthene	µg/L							
63	Benzo(ghi)Perylene	µg/L							
64	Benzo(k)Fluoranthene	µg/L							
65	Bis(2-Chloroethoxy)Methane	µg/L							
66	Bis(2-Chloroethyl)Ether	µg/L							
67	Bis(2-Chloroisopropyl)Ether	µg/L							
68	Bis(2-Ethylhexyl)Phthalate	µg/L							
69	4-Bromophenyl Phenyl Ether	µg/L							
70	Butylbenzyl Phthalate	µg/L							
71	2-Chloronaphthalene	µg/L							
72	4-Chlorophenyl Phenyl Ether	µg/L							
73	Chrysene	µg/L							
74	Dibenzo(a,h)Anthracene	µg/L							
75	1,2-Dichlorobenzene	µg/L							
76	1,3-Dichlorobenzene	µg/L							
77	1,4-Dichlorobenzene	µg/L							
78	3,3 Dichlorobenzidine	µg/L							
79	Diethyl Phthalate	µg/L							
80	Dimethyl Phthalate	µg/L							
81	Di-n-Butyl Phthalate	µg/L							
82	2,4-Dinitrotoluene	µg/L							
83	2,6-Dinitrotoluene	µg/L							
84	Di-n-Octyl Phthalate	µg/L							
85	1,2-Diphenylhydrazine	µg/L							
86	Fluoranthene	µg/L							
87	Fluorene	µg/L							
88	Hexachlorobenzene	µg/L							
89	Hexachlorobutadiene	µg/L							
90	Hexachlorocyclopentadiene	µg/L							
91	Hexachloroethane	µg/L							
92	Indeno(1,2,3-cd)Pyrene	µg/L							
93	Isophorone	µg/L							

CTR No.	Parameter	Units	Average Monthly Effluent Limitation	Maximum Daily Effluent Limitation	Maximum Concentration	Range	Method Detection Limit	Test Method	Number of Samples
94	Naphthalene	µg/L							
95	Nitrobenzene	µg/L							
96	N-Nitrosodimethylamine	µg/L							
97	N-Nitrosodi-n-Propylamine	µg/L							
98	N-Nitrosodiphenylamine	µg/L							
99	Phenanthrene	µg/L							
100	Pyrene	µg/L							
101	1,2,4-Trichlorobenzene	µg/L							
102	Aldrin	µg/L							
103	alpha-BHC	µg/L							
104	beta-BHC	µg/L							
105	gamma-BHC	µg/L							
106	delta-BHC	µg/L							
107	Chlordane (303d listed)	µg/L							
108	4,4'-DDT (303d listed)	µg/L							
109	4,4'-DDE	µg/L							
110	4,4'-DDD	µg/L							
111	Dieldrin (303d listed)	µg/L							
112	alpha-Endosulfan	µg/L							
113	beta-Endosulfan	µg/L							
114	Endosulfan Sulfate	µg/L							
115	Endrin	µg/L							
116	Endrin Aldehyde	µg/L							
117	Heptachlor	µg/L							
118	Heptachlor Epoxide	µg/L							
119-125	PCBs sum (303d listed)	µg/L							
126	Toxaphene	µg/L							

Influent Monitoring Location. _____ - Other Pollutants

Parameter	Units	Average Monthly Effluent Limitation	Maximum Daily Effluent Limitation	Maximum Concentration	Range	Method Detection Limit	Test Method	Number of Samples
TPH as gasoline	µg/L							
TPH as diesel	µg/L							
TPHs (other than gasoline and diesel)	µg/L							

B. EFFLUENT DISCHARGE DATA (for existing dischargers only) – Summarize effluent monitoring data for each effluent monitoring location (EFF-*n*) and list them sequentially.

Effluent Monitoring Location. _____ – Conventional and Non-Conventional Pollutants

Parameter	Units	Average Monthly Effluent Limitation	Maximum Daily Effluent Limitation	Maximum Concentration	Range	Method Detection Limit	Test Method	Number of Samples
pH	s.u.							
Turbidity	NTU							
Chloride	mg/L							
Total Dissolved Solids	mg/L							
Dissolved Oxygen	mg/L							
Chlorine Residual	mg/L							
Acute Toxicity	% survival							

Effluent Monitoring Location. _____ – Priority Pollutants

CTR No.	Parameter	Units	Average Monthly Effluent Limitation	Maximum Daily Effluent Limitation	Maximum Concentration	Range	Method Detection Limit	Test Method	Number of Samples
1	Antimony	µg/L							
2	Arsenic	µg/L							
3	Beryllium	µg/L							
4	Cadmium	µg/L							
5a	Chromium (III)	µg/L							
5b	Chromium (VI)	µg/L							
6	Copper	µg/L							
7	Lead	µg/L							
8	Mercury	µg/L							
9	Nickel	µg/L							
10	Selenium	µg/L							
11	Silver	µg/L							
12	Thallium	µg/L							
13	Zinc	µg/L							
14	Cyanide	µg/L							
16	2,3,7,8-TCDD (Dioxin)	µg/L							
17	Acrolein	µg/L							
18	Acrylonitrile	µg/L							
19	Benzene	µg/L							
20	Bromoform	µg/L							
21	Carbon Tetrachloride	µg/L							
22	Chlorobenzene	µg/L							
23	Chlorodibromomethane	µg/L							
24	Chloroethane	µg/L							
25	2-Chloroethylvinyl ether	µg/L							
26	Chloroform	µg/L							
27	Dichlorobromomethane	µg/L							
28	1,1-Dichloroethane	µg/L							
29	1,2-Dichloroethane	µg/L							
30	1,1-Dichloroethylene	µg/L							
31	1,2-Dichloropropane	µg/L							
32	1,3-Dichloropropylene	µg/L							
33	Ethylbenzene	µg/L							
34	Methyl Bromide	µg/L							
35	Methyl Chloride	µg/L							
36	Methylene Chloride	µg/L							
37	1,1,2,2-Tetrachloroethane	µg/L							
38	Tetrachloroethylene	µg/L							
39	Toluene	µg/L							
40	1,2-Trans-Dichloroethylene	µg/L							
41	1,1,1-Trichloroethane	µg/L							

CTR No.	Parameter	Units	Average Monthly Effluent Limitation	Maximum Daily Effluent Limitation	Maximum Concentration	Range	Method Detection Limit	Test Method	Number of Samples
42	1,1,2-Trichloroethane	µg/L							
43	Trichloroethylene	µg/L							
44	Vinyl Chloride	µg/L							
45	2-Chlorophenol	µg/L							
46	2,4-Dichlorophenol	µg/L							
47	2,4-Dimethylphenol	µg/L							
48	2-Methyl- 4,6-Dinitrophenol	µg/L							
49	2,4-Dinitrophenol	µg/L							
50	2-Nitrophenol	µg/L							
51	4-Nitrophenol	µg/L							
52	3-Methyl 4-Chlorophenol	µg/L							
53	Pentachlorophenol	µg/L							
54	Phenol	µg/L							
55	2,4,6-Trichlorophenol	µg/L							
56	Acenaphthene	µg/L							
57	Acenaphthylene	µg/L							
58	Anthracene	µg/L							
59	Benzidine	µg/L							
60	Benzo(a)Anthracene	µg/L							
61	Benzo(a)Pyrene	µg/L							
62	Benzo(b)Fluoranthene	µg/L							
63	Benzo(ghi)Perylene	µg/L							
64	Benzo(k)Fluoranthene	µg/L							
65	Bis(2-Chloroethoxy)Methane	µg/L							
66	Bis(2-Chloroethyl)Ether	µg/L							
67	Bis(2-Chloroisopropyl)Ether	µg/L							
68	Bis(2-Ethylhexyl)Phthalate	µg/L							
69	4-Bromophenyl Phenyl Ether	µg/L							
70	Butylbenzyl Phthalate	µg/L							
71	2-Chloronaphthalene	µg/L							
72	4-Chlorophenyl Phenyl Ether	µg/L							
73	Chrysene	µg/L							
74	Dibenzo(a,h)Anthracene	µg/L							
75	1,2-Dichlorobenzene	µg/L							
76	1,3-Dichlorobenzene	µg/L							
77	1,4-Dichlorobenzene	µg/L							
78	3,3 Dichlorobenzidine	µg/L							
79	Diethyl Phthalate	µg/L							
80	Dimethyl Phthalate	µg/L							
81	Di-n-Butyl Phthalate	µg/L							
82	2,4-Dinitrotoluene	µg/L							
83	2,6-Dinitrotoluene	µg/L							
84	Di-n-Octyl Phthalate	µg/L							
85	1,2-Diphenylhydrazine	µg/L							
86	Fluoranthene	µg/L							
87	Fluorene	µg/L							
88	Hexachlorobenzene	µg/L							
89	Hexachlorobutadiene	µg/L							
90	Hexachlorocyclopentadiene	µg/L							
91	Hexachloroethane	µg/L							
92	Indeno(1,2,3-cd)Pyrene	µg/L							
93	Isophorone	µg/L							
94	Naphthalene	µg/L							
95	Nitrobenzene	µg/L							
96	N-Nitrosodimethylamine	µg/L							
97	N-Nitrosodi-n-Propylamine	µg/L							
98	N-Nitrosodiphenylamine	µg/L							
99	Phenanthrene	µg/L							
100	Pyrene	µg/L							
101	1,2,4-Trichlorobenzene	µg/L							

CTR No.	Parameter	Units	Average Monthly Effluent Limitation	Maximum Daily Effluent Limitation	Maximum Concentration	Range	Method Detection Limit	Test Method	Number of Samples
102	Aldrin	µg/L							
103	alpha-BHC	µg/L							
104	beta-BHC	µg/L							
105	gamma-BHC	µg/L							
106	delta-BHC	µg/L							
107	Chlordane (303d listed)	µg/L							
108	4,4'-DDT (303d listed)	µg/L							
109	4,4'-DDE	µg/L							
110	4,4'-DDD	µg/L							
111	Dieldrin (303d listed)	µg/L							
112	alpha-Endosulfan	µg/L							
113	beta-Endosulfan	µg/L							
114	Endosulfan Sulfate	µg/L							
115	Endrin	µg/L							
116	Endrin Aldehyde	µg/L							
117	Heptachlor	µg/L							
118	Heptachlor Epoxide	µg/L							
119-125	PCBs sum (303d listed)	µg/L							
126	Toxaphene	µg/L							

Effluent Monitoring Location. _____ – Other Pollutants

Parameter	Units	Average Monthly Effluent Limitation	Maximum Daily Effluent Limitation	Maximum Concentration	Range	Method Detection Limit	Test Method	Number of Samples
TPH as gasoline	µg/L							
TPH as diesel	µg/L							
TPHs (other than gasoline and diesel)	µg/L							
Electrical conductivity	S/m							

X. ENGINEERING CERTIFICATION REPORT

Attach the engineering certification report signed and stamped by the Design Professional Engineer licensed to practice in California and as identified in section VI.D of the NOI. The Engineering Certification Report must include a location map, discharge flow path map, process flow diagram, unit specification sheets, and description of operation and maintenance procedures. Please see the next section for further details of the documents *required* as part of the Engineering Certification Report and NOI application package.

XI. INSTRUCTIONS FOR NOTICE OF INTENT FORM

These instructions explain how to complete the NOI. Submittal of an NOI indicates a Discharger's commitment to comply with the terms of this Order.

A. Certification

The person certifying the NOI form must meet the requirements described in Attachment D section V.B.2. *Review these requirements carefully.* Specific requirements apply to corporations, partnerships, sole proprietorships, and public agencies.

B. Application Fee and Mailing Instructions

The NOI is incomplete without the applicable permit fee. Submit the fee by sending a check payable to "State Water Resources Control Board" to the Regional Water Board address indicated on the NOI form. A separate fee is required for each non-contiguous site. At the time of permit reissuance, the application fee was **\$2,062**. The State Water Resources Control Board may modify the fee at any time. For the current fee, see http://www.waterboards.ca.gov/resources/fees/water_quality.

Submit this form (with signatures and attachments) [via email to R2NPDES@waterboards.ca.gov](mailto:R2NPDES@waterboards.ca.gov) or as otherwise indicated at www.waterboards.ca.gov/sanfranciscobay/water_issues/programs/general_permits.shtml.

C. Discharge Type

Select one of the three options to: (1) obtain coverage under this Order as a new Discharger, (2) modify the NOI as an existing Discharger, or (3) renew permit coverage. Please note that the Discharger shall file with the Executive Officer an amended NOI at least 30 days before making any material change in the character, location, or volume of the discharge. Requests to renew permit coverage shall be submitted no later than April 5, 2023.

Select one of the three categories for type of discharge. Permit requirements are dependent on the category of discharge.

D. Project Information

Provide a brief description of the project and activities to be covered by this Order, including its completion date, if any.

E. Utility Information

Provide information of the local utility agencies that were contacted for the proposed discharge. Please note that Resolution No. 88-160, adopted by the Regional Water Board on October 19, 1988, urges dischargers of extracted groundwater to reclaim their effluent and that when reclamation is not technically and/or economically feasible, to discharge to a publicly-owned treatment works.

F. Facility Information

- 1. Facility name.** Provide the name of the treatment facility, street address or a description of the facility location, and information of the contact person for the facility.

2. **Duly Authorized Representative.** The person described in Attachment D section V.B.2 and signing the certification in section I of the NOI form may designate a duly authorized representative to sign permit-related submittals in accordance with Attachment D section V.B.3. Alternatively, a duly authorized representative may be designated through separate correspondence, particularly if the NOI form language does not sufficiently limit the delegated authority. For applicants, please note that if a duly authorized representative is designated, a written authorization shall be submitted to the Regional Water Board along with the NOI. If any changes occur to the authorization, a new authorization satisfying the requirements under Attachment D section V.B.3 must be submitted to the Regional Water Board prior to or together with any reports, information, or applications signed by a duly authorized representative.
3. **Billing information.** Indicate to whom the annual permit fee should be billed.
4. **Design Professional Engineer's Information.** Provide the name and contact information of the practicing professional engineer licensed to practice in California who designed the groundwater treatment system and certified the Engineering Certification Report. The Design Professional Engineer is also responsible for certifying any proposed changes to the groundwater treatment system.
5. **Operation and Maintenance Professional Engineer's Information.** Provide the name and contact information of the professional engineer licensed to practice in California who is responsible for the operations and maintenance procedures of the treatment facility and certification of its Operations and Maintenance Manual.
6. **Consulting Firm's Information.** Provide the name and contact information of the consultant working on behalf of the discharger.

G. Discharge Location Information

Provide a brief description of the discharge flow path from the exit point of the treatment system to the outfall(s) in the receiving water(s). Identify all points where the facility discharges wastewater to surface waters or storm drains and provide latitudes and longitudes (using decimal degrees with at least five decimal places). Identify the receiving waters to which discharges flow into (permitted discharges may flow through storm drains if authorized by storm drain system owners) and confirm if access to the receiving water(s) are unrestricted. Attach additional pages as necessary.

H. Treatment System Information

1. **General information.** Provide the groundwater treatment design capacity as certified by the Design Professional Engineer licensed to practice in California and as identified in section VI.D. Additionally, provide a narrative description of potential pollutants in the discharge. Finally, specify the frequency of discharge and estimated percentage of total effluent reclaimed for any applicable activities such as dust suppression, soil compaction, irrigation of landscape or agriculture, and industrial water supply. Please note that water reclamation consisting of recharge or reinjection is not authorized under this Order.
2. **Unit information.** Provide information on the quantity and type of units in the groundwater extraction and treatment system including any applicable characteristics such as size, capacity, ratings, depth, dosages, etc.

I. Engineering Certification Report

The Engineering Certification Report must be a comprehensive report detailing the process and components of the groundwater extraction and treatment system. It must provide background information regarding the site and project, and a summary of any environmental investigations of groundwater impacts at the site, if any. The description of treatment system components must include any dewatering wells, groundwater pumps, conveyance systems, storage tanks, settling tanks, process pumps, filtering vessels, granular activated carbon tanks, chemical injection systems, and pH adjustment equipment. Additionally, it must include the following:

- A. Location map.** A topographic map (or maps) showing the legal facility boundaries, location of treatment units and processes, intake and discharge point locations, and receiving waters (or storm drains).
- B. Discharge flow path map.** An aerial map or satellite image illustrating the proposed path of the discharge from the point of exit of the treatment system to the point of discharge in the receiving water. All applicable streets, land features, points of entry in the storm drain system, receiving waters, and distances must be labeled and displayed on the map.
- C. Process flow diagram.** A diagram showing the water flow from intake to discharge, including all treatment system components and applicable sampling ports (see example below). The diagram must indicate how the discharge flows from where it is generated to where it exits the treatment system and include approximate flows.

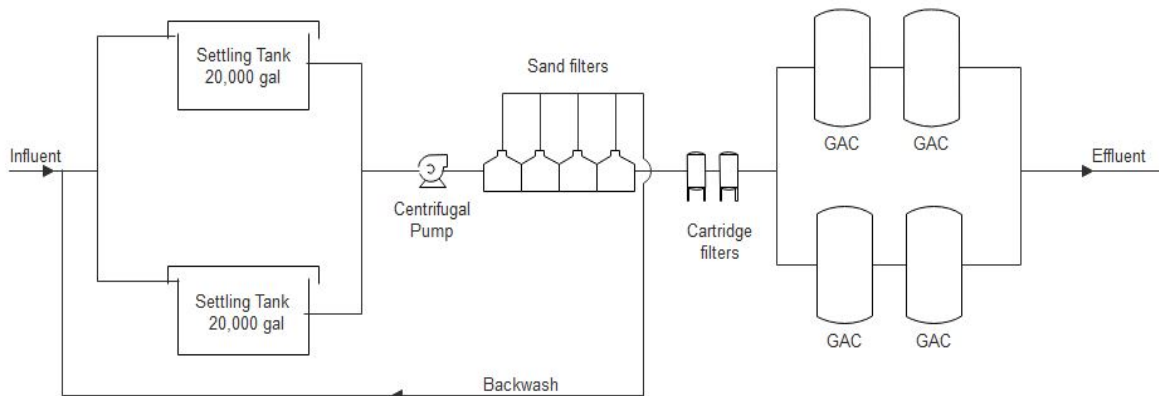

- D. Unit specification sheets.** Datasheets that provide engineering characteristics of each treatment system unit.
- E. Operation and maintenance procedures.** A copy of the Table of Contents from the Operation and Maintenance Manual of the treatment system.

The Engineering Certification Report shall certify the adequacy and reliability of the treatment system and comply with the Order's requirements. Finally, as required by the California Business and Professions Code section 6735, the report shall be prepared by, or under the supervision of, a Professional Engineer licensed to practice in California and shall be signed and stamped by the same.